

### BRASS CABINET HANDLES

Product codes:	6502	6503	6504
	6508	6509	6510
	6514	6515	6516

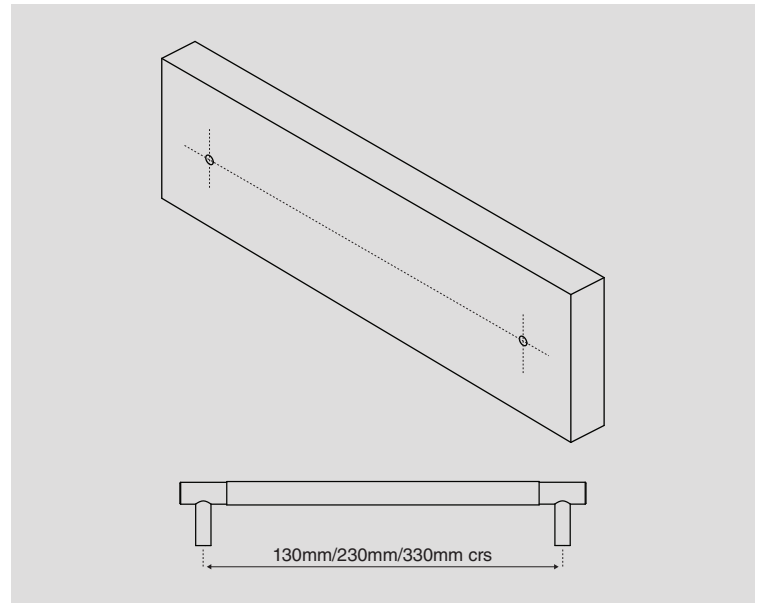
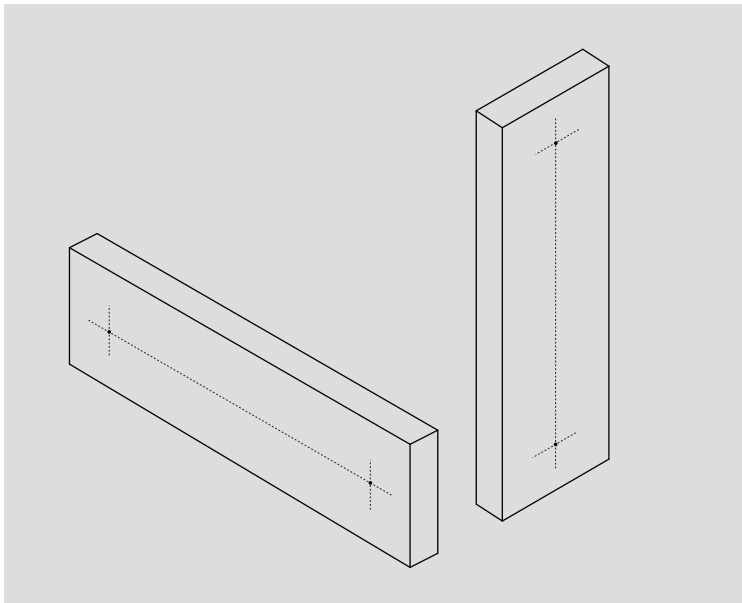

- Includes:**
- 1x Cabinet Handle
  - 2x M5 Fixing Screws\*
  - 2x Washers
  - 2x Mounting Discs (optional)

**1.** Mark the fixing position for the cabinet handle on the door/drawer. They can be installed horizontally or vertically depending on the desired look.

Ensure adequate space is provided for clearance of knuckles when opening cabinetry.

**2.** Drill two 5.5mm diameter holes at the marked fixing positions for the leg centres.

**160mm Handles**

6502, 6508, 6514 - 130mm crs

**260mm Handles**

6503, 6509, 6515 - 230mm crs

**360mm Handles**

6504, 6510, 6516 - 330mm crs

\* non standard cabinet thicknesses may require longer screws.

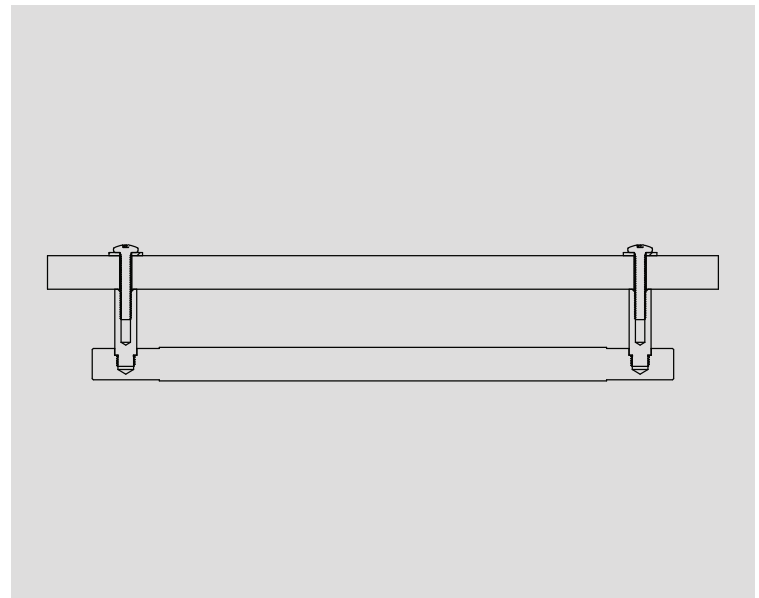
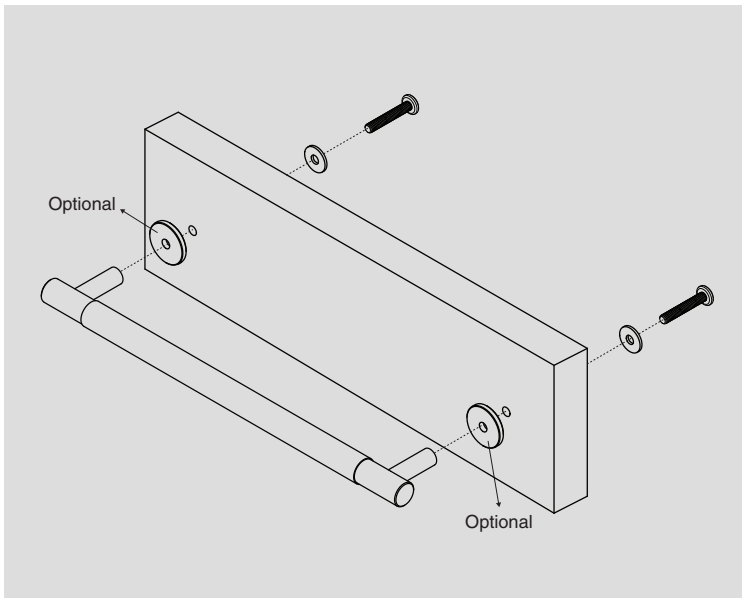

**3.** Hold the cabinet handle and align the legs with the pre-drilled 5.5mm diameter holes.

Insert two M5 fixing screws from the rear of the cabinet front, ensure washers are installed between the screw head and cabinet.

Install mounting discs (optional) or backing plates\* between the cabinet handle leg and cabinet front.

Thread the screws into the cabinet handle legs and tighten using a screwdriver to fix in position.

**4.** Ensure that you do not overtighten the screws.

**Backing Plate Codes**

6526 - 160mm

6527 - 260mm

6528 - 360mm

\* For retro-fitting backing plates can be ordered separately see product codes below step 4.