

### ASTRON PASSAGE SET

Product codes: 7033 | 7036 | 7042  
7051 | 7059 | 7107 | 7114 | 7150

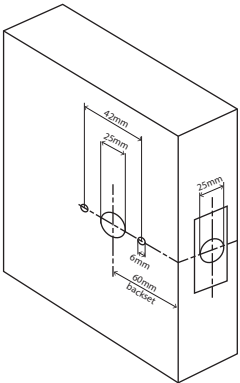

1. Measure the door thickness and mark the centre at the desired height for the latch.
2. Drill a 25mm (1") diameter hole through the door edge to a depth of at least 90mm. Ensure this hole is square to the door.
3. Mark the face of the door each side for drilling a 25mm diameter spindle hole. The centre of the spindle hole will need to be 60mm from the door edge (backset). For clean cut-outs, drill from both sides, meeting in the middle of the door. Mark and drill two 6mm screw holes at 21mm to the left and to the right of the centre of the spindle hole.

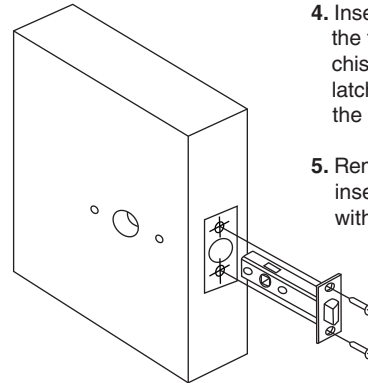

4. Insert the latch, scribe around the faceplate, remove, then chisel out recess to enable the latch faceplate to sit flush with the door edge.
5. Remove any loose saw dust, insert the latch and secure it with the wood screws provided.

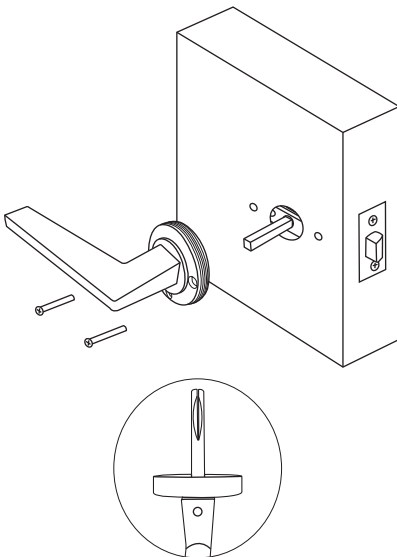

6. Unscrew the rose covers from the levers and unscrew the bolts from the screw caps.
7. Insert the spindle into the latch so an even amount protrudes on each side of the door. Ensure the grooved side of the spindle will align with the grub screws on the handles.
8. Insert the long through fixing bolts through the face of the handle at two horizontal positions. Slide the handle over the spindle and press against the door.

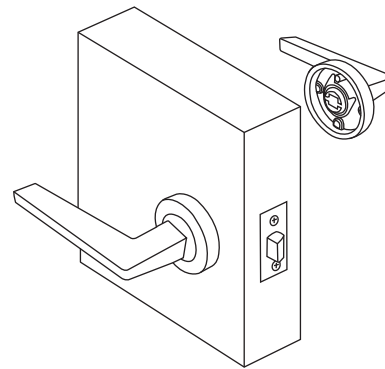

9. Trim the bolts to the correct length if necessary. Insert the handle on the opposite side of the door over the spindle. Insert the screw caps and tighten the long bolts through into these caps.
10. Screw the rose covers onto the handles and tighten the grub screws on the side of the levers onto the spindle for each side of the door.

*Note: The grub screws may need a re-tighten after a bedding-in period. We recommend medium strength thread-lock to be used, Windsor code:1276*

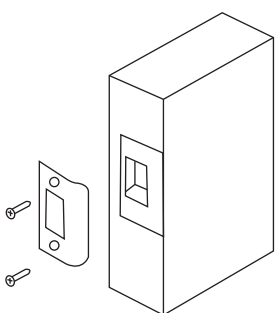

11. Close the door against the frame and mark the latch position for fitting of the striker.
12. Router or chisel so the striker fits flush, allowing for the plastic dustbox behind the striker.
13. Secure the striker with the wood screws provided. Test the door and if necessary, adjust the striker anti-rattle tab to take up any rattle.